



sequoia

“Compromising Quality against our Values”



COMPANY PROFILE

Sequoia Metalics Private Limited began its operation in 2022 in India. We started as a small team but the start doesn't necessarily determine the end, we are a fully-fledged company with the ambition to global reach. The company has today in a growing stage with 10(+) people and is well known as a reliable partner in all its active fields of Scaffolding, Shuttering, Formwork and Engineering Services.

OUR VISION

To create simpler and more affordable formwork and scaffolding solutions for the construction industry, servicing you through sourcing and supplying the best solution for all our clients.

OUR MISSION

- To identify and focus on the challenges the industry faces
- To source, implement and supply solutions for these challenges
- To provide a professional and reliable service to the industry
- To service the industry with integrity and humility
- To provide a “one-stop-shop” for all scaffolding needs

Telescopic Steel Props :

Telescopic Steel Prop can be used on all types of building construction or for any type of use where an adjustable vertical load bearing member is required. They are most ideal and economical supporting device for all kinds of formwork to Slabs, Beams, Walls and Columns.

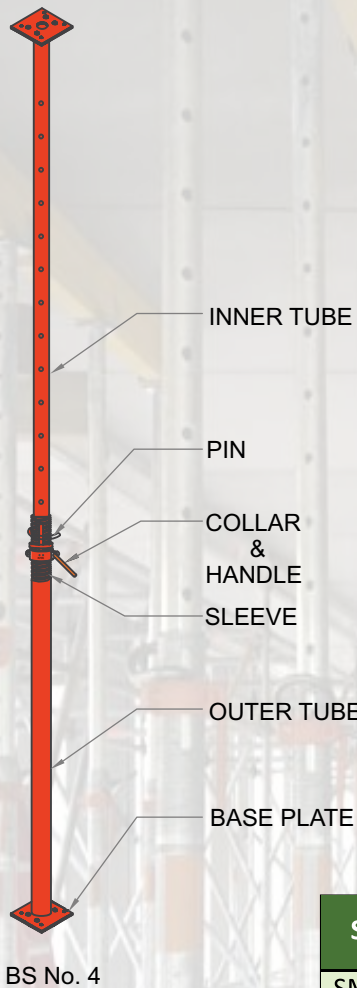

Type of Prop Heads



Sizes	Outer in MTR	Inner in MTR	Closed in MTR	Extended in MTR	Self weight in KG
SMPL-1	1.00	1.00	1.10	1.75	10.00
SMPL-2	1.50	1.50	1.50	2.75	13.80
SMPL-3	1.50	2.00	2.00	3.25	15.50
SMPL-4	2.00	2.00	2.00	3.75	17.80
SMPL-5	2.00	2.50	2.50	4.25	19.40
SMPL-6	2.00	3.00	3.00	4.65	21.00
SMPL-7	2.50	2.50	2.50	4.65	21.80
SMPL-8	2.50	3.00	3.00	5.10	23.40
SMPL-9	3.00	3.00	3.00	5.60	25.50

Note: Weights indicated above are subjected to tolerance of +/-

***Other sizes can be offered on request**

Specification:

- Outer tube made of 50NB (Ø60.3mm) Medium Class Pipe.
- Inner tube made of 40NB (Ø48.3mm) Medium Class Pipe.
- Top and Bottom Plate are made of 150X150X6 mm M.S. Plate.
- Heavy Duty Malleable Cast-Iron Prop Nut gives fine adjustment for levelling.
- “G” Pin made of 'High Tensile' Steel provided for coarse adjustment.

Additional features

- Our Roll*Threaded Props ensure no loss of material by which life and load bearing capacity of the prop is effectively enhanced.
- As per customer's needs, Props are available with various heads like Beam Head, “U” Head, Angle Head, Regular Flat Head and Tilt-Up Head.
- We also make available “Deep Painted” Props using Synthetic Enamel Paint.

Safety Instructions

- Props should always be plumb and loaded concentrically.
- Safe working loads allow 1.5 out of plumb loaded concentrically.
- Props must be braced in both directions by tubes and Double couplers when extended beyond 3.75 Meters.
- Lacing to be done at $1/3^{\text{rd}}$ the height of extended inner section and to be both direction.
- While Double staging, lower prop shall be braced at two level s whereas upper Prop, at one level. All these three bracings have to be in both directions.

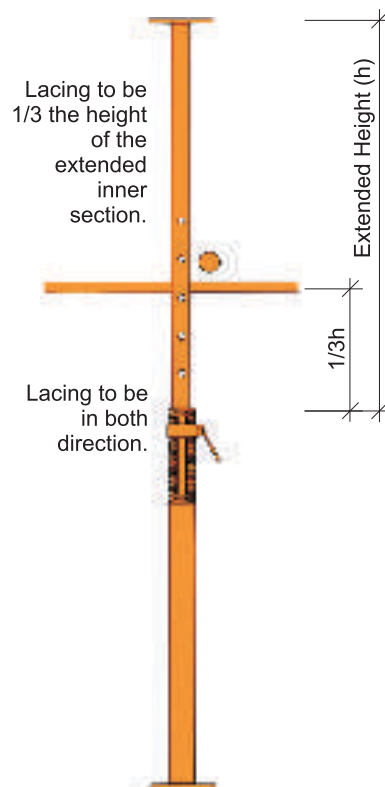

Adjustable Beam Span :

Adjustable Beam Spans are widely used as self-supporting runners in the shuttering system under the Floor form Panels/Shuttering Plates

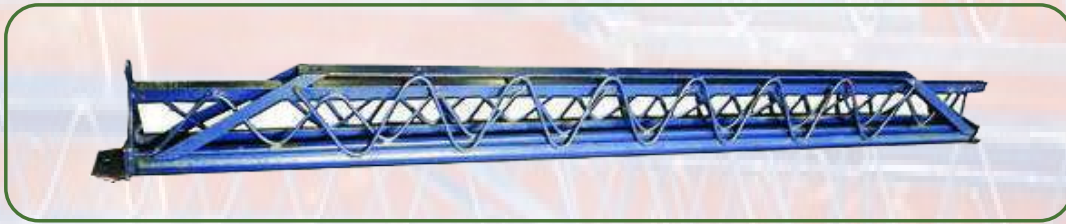

Adjustable Span Components

Two Basic Components

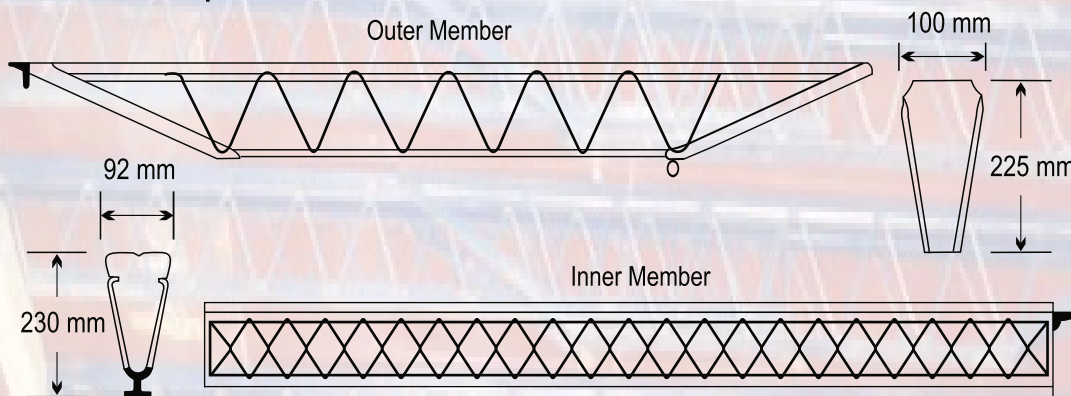

Outer and Inner Members (length & Weight)			
Extra short outer	ESO	1580mm	13.00 kg
Short outer	SO	2490 mm	24.00 kg
Long outer	LO	3000 mm	28.00 kg
Extra short inner	ESI	1730 mm	18.00 kg
Short inner	SI	2500 mm	25.00 kg
Long inner	LI	3100 mm	33.00 kg

Note: Weights indicated above are subjected to tolerance of +/- 3 %

Specification:

Main body of the Outer and Inner members are made up of 14/12 Gauge M.S. Sheet.

Bottom of outer member is made up of 50x6 mm M.S. Plate.

Bottom of the Inner member is produced, using 40x40x6 mm "T" Angle.

Lattice is made of 10mm dia M.S. Round Bar.

Bearing Angle are of 75x75x8.

Safety Instructions

No intermediate support required.

Maximum bending moment 1040 kg.m.

Maximum total load 2700 kg.

Factor of safety 2:1.

- Exceptionally high load bearing capacity despite its low weight
- Gives maximum safety with minimum supervision
- Eliminates repetitive investment through cutting and wastage of timber
- Withstands rough site handling
- No intermediate vertical shoring - free access below
- Assured load bearing capacity
- Compact for storage and transport

***Other sizes can be offered on request**

Floor-Form Panel/Shuttering Plate :

Floor-Form Panels are used as shuttering for slab casting, Floor-Form adjusters fill up odd shapes of slabs eliminating cutting and wastage of timber altogether.

Floor-Form Panels are made of 14/12 Gauge M.S. Sheets with double bent edges of 38mm Height welded at all corners with proper slots and nail holes at the edges. In order that the flange stays as a one piece product and maintains its strength, It is pressed bent from the same M.S. Sheet.

Floor-Form Adjusters are normally 400mm and 250mm wide and 900mm and 1150mm long. Details of standard sizes of Floor-Form Panels available and their respective allowable slab thickness are given in the table below.

Customized sizes can also be made available as per client's requirements

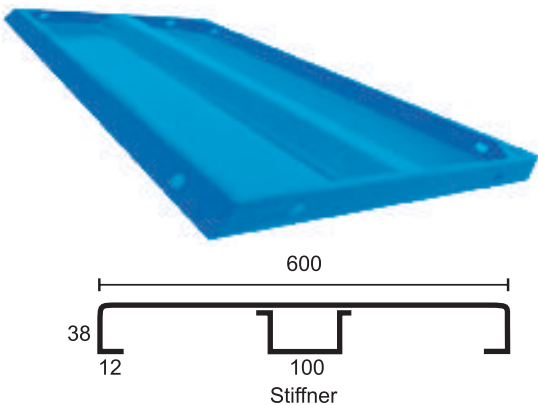

FloorForm Panel Size (mm)	Self Weight (mm)	Span (mm)	Max. Slab Thickness (mm)
1150x600	16.65	1150	300
1000x600	16.00	1000	350
900x600	12.95	900	400
800x600	12.50	600	600

Note: Weights indicated above are subjected to tolerance of +/- 3 %

Span: C/c unsupported distance between the two horizontal runners on which the plate lie.

Thickness: Maximum Allowable Slab thickness of the slab to be cast

- Ideal for slab shuttering
Cuts labour costs
- Gives excellent concrete finish
- Speeds up work
- Light weight yet rigid & strong
Easy maintenance
- Eliminates repetitive investment on plywood

Safety Instructions

- Before using old Sequoia spans, check all welds for soundness
- Make sure the locking screw is tightened properly
- Make sure bearer plates are resting firmly on the support
- Ensure that the runners supporting Sequoia span bearer plates are adequately strong and transfer loads to the supporting Props.

Cuplock Scaffolding System:

Cuplock is proven multipurpose scaffolding system which can be used in structures for building and construction industries. It is the most versatile and optimized system of scaffolding.

(A) Cuplock Verticals/Standards :

Cuplock Verticals are the principal load bearing members comprising of Sets of Top and Bottom Cups. The Bottom Cups are welded in position at 500/1000 mm distance. The Top Cups are movable and retained by a fix stop. The Verticals are made of 40NB Medium/Heavy Class pipes and are drilled for the fixing of Spigot Joints at both the ends.

Load Carrying Capacity of Cuplock Verticals		
Bracing Length	Permissible Load in Tons (Yst 210 N/mm ²)	
	"Medium Class"	"Heavy Class"
500	4.66	6.32
1000	4.12	5.57
1500	3.54	4.74
2000	2.67	3.50

Note: The above values are indicatives and not accurate. We request you to re-confirm these loads before finalizing your cuplock staging design.

Sizes of Cuplock Verticals/Standards		
Sizes (mm)	No. of Cups @ 500/1000mm	Self-Weight in KG/Nos
3000	6/3	13.40
2500	5/3	11.20
2000	4/2	9.00
1500	3/2	6.80
1000	2/1	4.60
500	1/1	2.40

Note: Weights indicated above are subjected to tolerance of +/- 3 %

***Other sizes can be offered on request**



(B) Cuplock Ledgers/Horizontal:

Ledgers/Horizontal are made of 40NB Light/Medium Class pipes with forged Ledger blades welded at both the ends. The Simple robust design ensures that Ledgers/Horizontal need no maintenance.

Length of the Ledgers/Horizontal is calculated between Centre to Centre of such two Verticals.

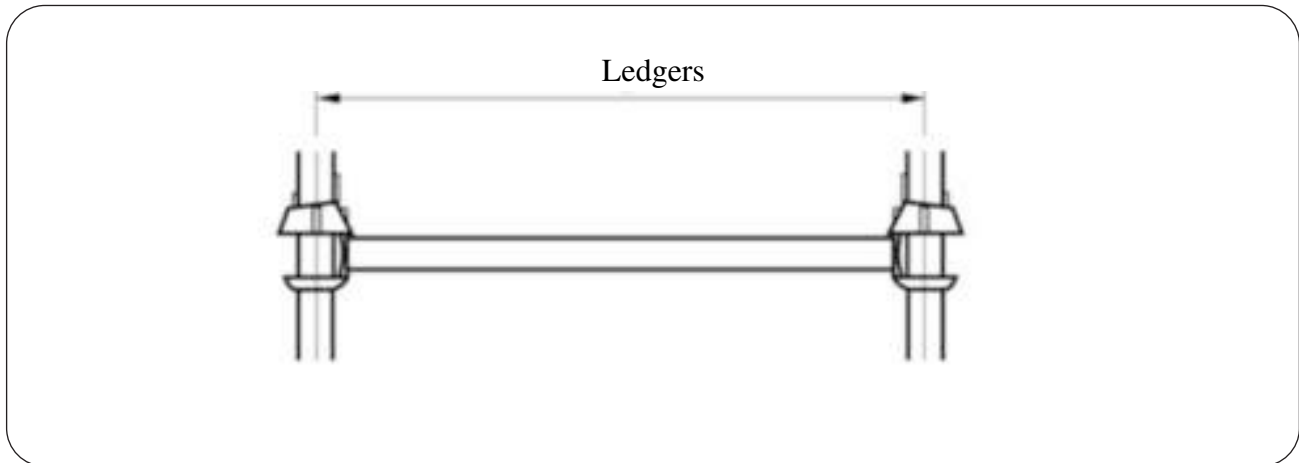

Cuplock Ledgers / Horizontal

Sizes of Cuplock Ledgers/Horizontal		
Sizes (mm)	Length in mm	Self-Weight in KG/Nos
2500 C/c	2452	8.70
2000 C/c	1952	6.90
1800 C/c	1752	6.20
1500 C/c	1452	5.30
1200 C/c	1152	4.30
1000 C/c	952	3.70

Note: Weights indicated above are subjected to tolerance of +/- 3 %

- Easy to maintain
- Quick & easy to erect. Erection can be done even by unskilled labour
- Faster erection time than traditional scaffolds
- High resistance to wear & tear
- Suitable for straight, curved & circular configuration
- Excellent for use as access scaffolding & slab support staging

***Other sizes can be offered on request**

Cuplock Cantilever Frames and Hop-Up Brackets :

Cantilever frames are used for supporting decking or formwork at the edge of the slabs. The frames have blade ends for locating the cup joints and can accept Jacks. Such frames can have projection up to 1.5M.

Hop-up Brackets are smaller version of Cantilever frames. They are generally used for awkward areas beyond the main scaffolding where scaffolds cannot be located directly adjacent to the work face.

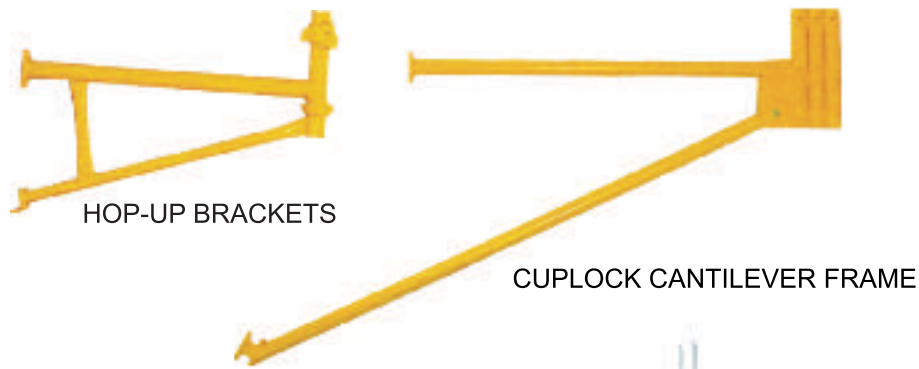

Heavy Duty Soldier

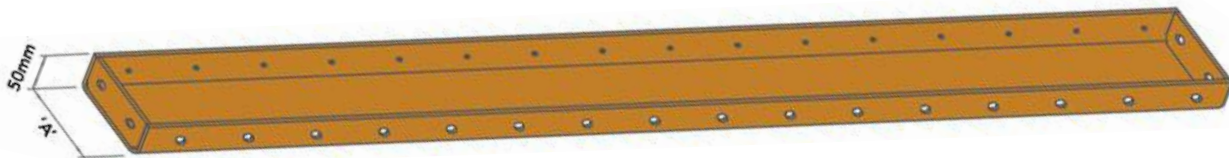

Specification

Channel Soldiers made out with Channel of size 100x50x6mm with MS Plate 5.0mm thickness.

- It is available in 100mm x 2000mm, 2500mm & 3000mm long as per customer requirement.
- It is provided with holes on sides to match that of the Wall Form Shuttering for quick assembly & dismantling.

Walkway Planks:

A Walkway Plank is an equipment which typically provides access through an opening, by permitting mobility and communication. Its main purpose is to facilitate a person to stand, move and work conveniently, without any difficulty, along with the machinery utilized to carry out the job.



Gratings

Gratings is a framework of parallel and crossed bars, that can also be utilized as a walkway plank. Usually such gratings are made of 25x25/20x20x1.5 mm thickness M.S. Pipes and 20NB Round Pipes of varied thickness, based on clients requirements.

Scaffolding Board:

Scaffolding Boards Image Scaffolding Boards are made of 14 Gauge M.S. Sheets and double bent edges, welded at all corners with percolated anti-slip dimples over the upper surface of the walkway.

**Two types – Hook,
without hook**



Available Sizes

2700x300 mm
2400x300 mm
2100x300 mm
1800x300 mm
1500x300 mm

***Other sizes can be offered on request**

H-Frame Scaffolding System :

An assembly that consists of rigid welded frame of two Vertical and Horizontal pipes which are interconnected by scissor type Cross Braces through Pins and Spring Clips is called as an “H” Frame Scaffolding System.

Sizes of "H" Frames	
Size (HxW) in mm.	Self-weight in KG/Nos.
2000x1000	21.40
2000x1250	23.00
2000x2000	28.00
2400x1000	28.60 [^]
2400x1250	30.35 [^]

Note: Weights indicated above are subjected to tolerance of +/- 3 %

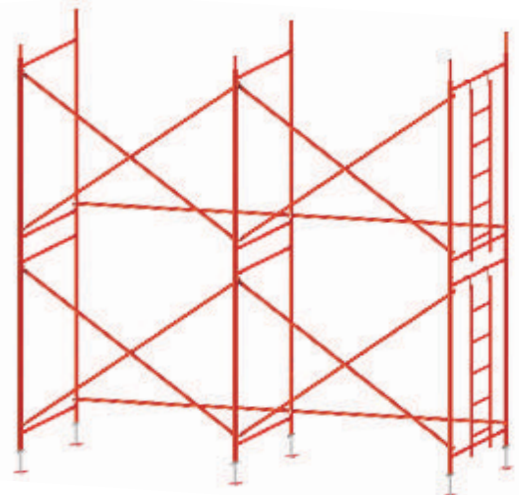

Sizes of Cross Braces

Size (AxB) in mm.	Spacing in mm	Length (L) in mm	Pipe Dia	Self Wt. in Kgs.
2500x1500	2500	2950	25NB 20NB	9.25 7.50
2000x1500	2000	2550	25NB 20NB	8.00 6.45
1250x1500	1250	2000	25NB 20NB	6.35 5.15

Note: Weights indicated above are subjected to tolerance of +/- 3 %

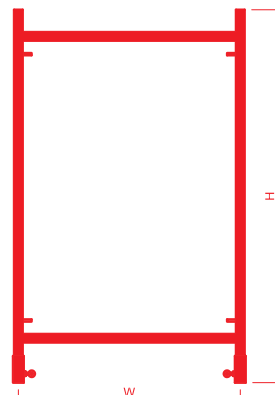

Standard 'H' Frame

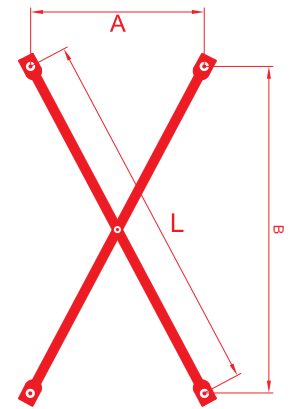

Cross Bracing

Specifications:

The Verticals are made of 40NB Medium/Heavy class pipe and Horizontals are made of 40NB Light/Medium class pipes. In order to connect two "H" frames vertically 50NB Socket or 38OD Spigots are welded at one end of both the verticals. Cross Bracings are made of 25/20Nb Medium or Light class pipes.

Apart from the regular type of "H" Frames, we also provide Walkthrough Frames and Ladder Frames. Walkthrough frames provide an easy access for human mobilization with clear head room throughout the erected scaffolding structure. Ladder frame facilitates working platforms at different heights by fitting walkway planks on Horizontals located at multiple levels of the frame.

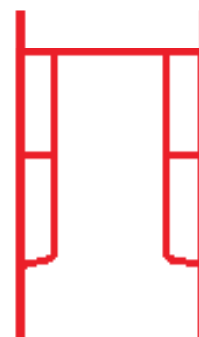
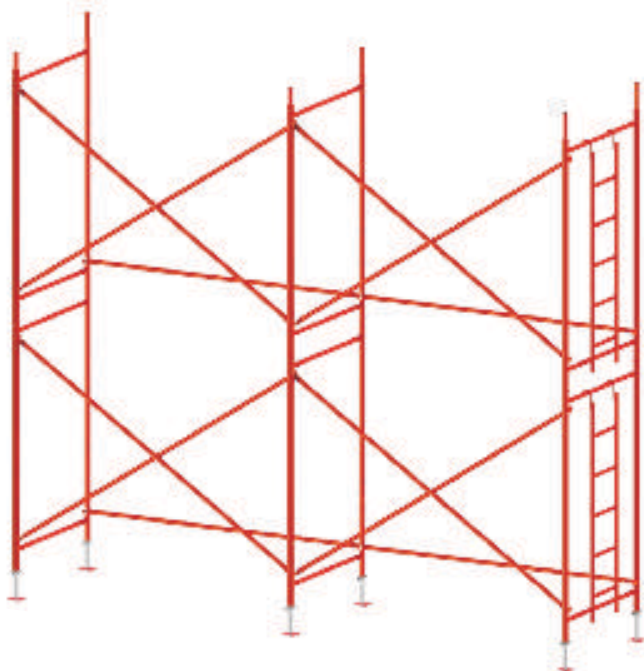

Walk Through Frames



Ladder / Mason Frames

Wallform Panels/Plates Formwork System:

Wallform is ideal for heavy and light duty multi-purpose formwork which gives maximum economy with excellent concrete finish.

Wallform system of steel shuttering comprises of Standard Panels of different sizes with longitudinal Stiffener, Channel or Heavy Duty Soldiers and Tubes or Channel Walers. All these components are assembled together by four types of Clips of unique design.

Wallform panels are manufactured out of 2.5/3.0 mm thick M.S. Sheets with Slotted M.S. Angle of 45x45x5 mm or 50x50x6 mm sizes.



We also made



Haunch Plate



Curved Plate
(PHE)



Round Column
Plate



Corner Plate

Available Sizes (mm)	Weight in KG
1250x1000	61.80
1000x1000	57.50
1250x600	34.00
1250x500	29.90
1250x300	25.60
1200x600	23.80
900x600	18.80

Note: Weights indicated above are subjected to tolerance of +/- 3 %

***Other sizes can be offered on request**

Scaffolding Cribs:

Scaffolding Cribs, which are mainly used for staging purposes in the construction of flyovers, buildings, and bridges. These are suitable to employ in designing of tunnel Formwork, small and big underpass, small and big culvert. Having made out of the finest grade mild steel, these cribs are long-lasting and rugged. **Scaffolding Cribs** do not degrade in quality or become inferior in the long run

Cribs easily stand up to any rough industrial and erection environment And strong and rigid cribs are also hold heavy load structure slab for vertical load. Cribs made from heavy duty angle 65 mm X 65 mm X 6 mm thick and 12 mm to 18 mm rod for cross support



Drainage Spout:

Drainage spout is used for transmitting rainwater down from a roof gutter to a drain.



Sizes in mm.	Pipe Dia	Length in mm
210x210	100	300
210x210	150	600
180x305	150	100
200x150	50	300
200x150	50	400
300x300	100	400



Structural Steel:

Structural steel is a **category of steel used for making construction materials in a variety of shapes**. Many structural steel shapes take the form of an elongated beam having a profile of a specific cross section.

Structural steel is a **carbon steel, meaning it has a carbon content of up to 2.1 percent by weight**. After iron, carbon is the most important element in carbon steel. Increasing the amount of carbon in the composition of steel results in materials that have high strength and low ductility.

(A)M.S. Pipe:

Mild steel pipes or MS pipes are used for the purpose of plumbing, firefighting, heating, ventilation and air conditioning. These pipes are perfectly suitable in several industries and various engineering applications.

These pipes are manufactured using low carbon (less than 0.25%) steel and that is the reason why they do not harden and are hassle-free and easy to use. **MS pipes** can also be welded to various shapes and sizes for the purpose of pipelining and tubing.



Here are some of the salient Features of MS Pipes –

- They feature high tensile strength and are extremely sturdy
- Contains a low percentage of carbon
- It can be easily welded
- Easy to fabricate and readily available
- Best quality MS pipes ensure around 100 years of lifespan
- Budget-friendly.

These pipes are usually coated with metals, paints, varnish etc. to prevent it from rusting under extreme condition and make them long-lasting and durable.

ISMC (“C” Channel)

MS Channel is widely used for structural support in construction works and is made by using high-quality mild steel. As against its counterparts, Mild steel delivers a great performance and is best known for its versatility and cost effectiveness. It is the world's most common form of steel and its applications are varied and are relied upon every day.

MS Channels or commonly known as C- channel, because of their C like shape is represented by its Web height & Flange width of the channel. MS Channel primarily carries horizontal gravitational forces and is used for bus body, EOT cranes and many more engineering industry needs.

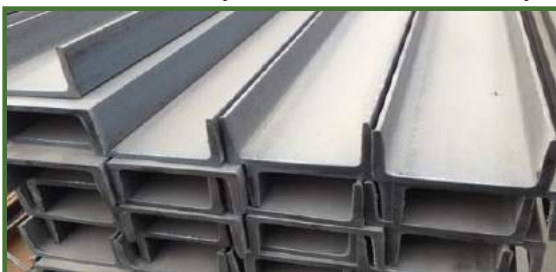

- For enhancing and edging projects.
- Durable and reliable finish.
- Suitable for covering different construction applications.
- Channels contain a very low content of carbon which impart them with stiffness and high strength.

M.S. Angle :

MS angle or mild steel angle is an **L-shaped cross-section used in the construction of various structures and buildings**. The most commonly used MS angle or metal angle is the one that forms a 90-degree angle with two sides of equal length and width.

Mild steel angles are manufactured by hot-rolled carbon steel or high strength low alloy steel that gives them great stability for various structural applications and other general fabrication repair works. It is widely used in commercial , Industrial, domestic, and other engineering applications.



M.S. Sheet:

MS Sheets are excellent quality material that withstands all type of climate and obstructions. It has high rigidity and is manufactured in different length, thickness , weight as per the needs of the customers. MS Sheets have high tensile strength and are very effective against corrosion as it has a protective zinc cover when galvanized, It is perfectly suitable for drilling , cutting, and welding.

It is widely used for a number of purpose in various industrial applications such as chemicals, fertilizers, distilleries, cement industries, petrochemicals, automotive and more. As compare to other type of steel, they are also relatively cost-effective and more preferred for use.

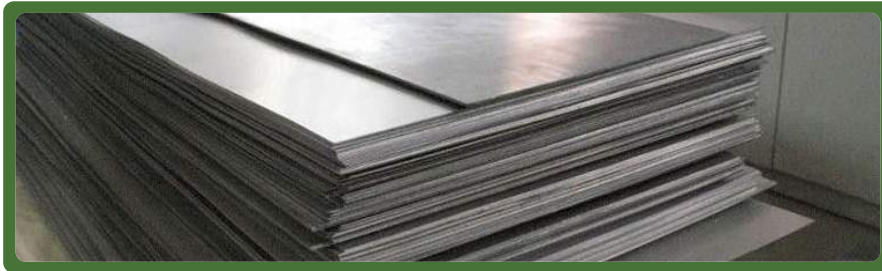

M.S. Flat:

Mild steel flats are considered to be the most cost-effective and fundamental form of steel structures. M S flats are basically **thin strips of mild steel with the thickness ranging from 6mm to 25mm** however thicker flats are likewise accessible.

It is flexible from of steel that is suitable for a wide range of fabrication applications as it has an exceptional combination of strength and versatility. Finding the best quality MS flat was a bit difficult earlier, but not anymore.



M.S Round Bars:

Mild Steel Round Bars contain a very low carbon content and are highly machinable forms of metal. The major property of MS Round Bar is that **it has high adaptability that gives the flexibility to shape them as required**. They can also be easily welded as compared to high carbon content steel that requires specific methods and extra manpower to weld the material. Another useful feature of the MS Round Bars is that it is highly economical hence it is widely used for a majority of applications especially for automobile ancillaries, motorcycle frameworks, and industrial use etc.



ISMB

I beam is a **shape of structural steel used in buildings** and it is also known as H, W, wide, universal beam, or rolled joist. They are designed to play a key role as a support member in structures. These beams have the capacity to withstand various types of loads.

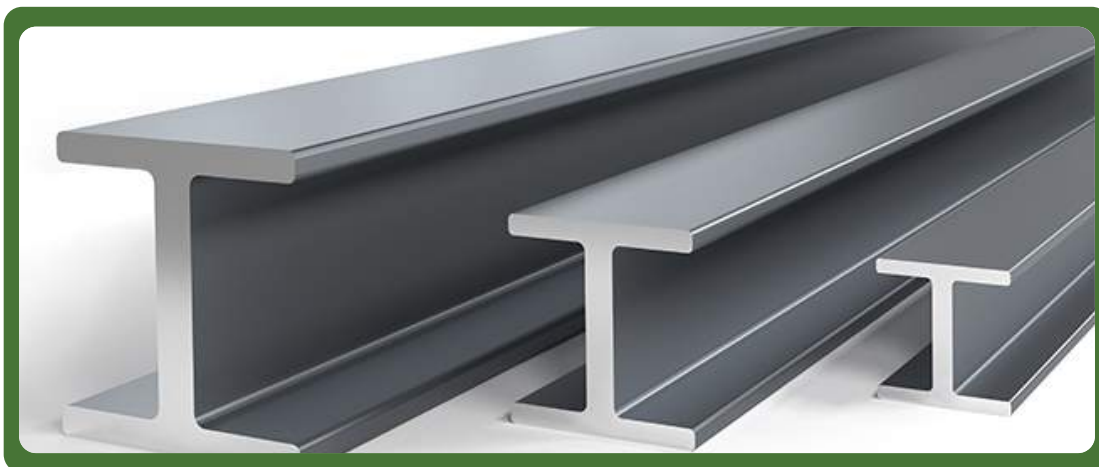

Its name was given so because of the resemblance of its cross-section to the letter I. These beams are frequently utilized to form beams and columns in a variety of dimensions and specs. It is crucial for civil engineers and foremen to understand the importance of I beams in steel structures.

Scaffolding/Construction Accessories:



Stirrup Head Jack



Base Jack



Fixed Base Plate



**Double Coupler
(Sheet Metal)**



**Swivel Coupler
(Sheet Metal)**



Spigot/Joint Pin



Hand Trolley



**Foundation Bolt
(Tailor Solution)**



Binding Wire



Tie Rod



Wing Nut



Anchor Nut



Prop Nut with Handle



Prop Sleeve



G" Pin



Waller Plate



Water Stopper



Shuttering Clamp (Sikanja)



Jack Nut



Drop Forged Swivel Coupler



Drop Forged Double Coupler



Ledger Blade



Top Cup



Bottom Cup

WHY CHOOSE US



TIMELY EXECUTION

We give you a defined timeline and stick to it



HONEST ADVICE

Our team will give you honest advice with goals in mind



TRANSPARENT PRICING

What you see, is what you pay. No. hidden charges.
Period



UN-COMPROMISED QUALITY

Best-practices used to ensure quality



EXPERT MENTORSHIP

Mentorship from industry experts and experienced professionals



SEQUOIA

“Compromising Quality against our Values”

SEQUOIA METALICS PRIVATE LIMITED

Registered Office: C/o Ushlekh Manikpuri, Near Talab Main Road, Gondwara Raipur,
Chhattisgarh 493221 India.

Website: www.sequoiametalics.com

E-mail : info@sequoiametalics.com

Contact : 0771-4338621,+91-76-111-20-444, +91-76-111-93-444